

A Wearable Context-Awareness Component

Finally a Good Reason to Wear a Tie

Albrecht Schmidt, Hans W. Gellersen, Michael Beigl
Telecooperation Office (Teco), University of Karlsruhe, Germany
albrecht@teco.edu

Abstract

We describe the design of a wearable context-awareness component that derives general context information from low-level sensors. Derived context information is application-independent and can be used by wearables or other personal technologies in a body network via a simple protocol. We built the context-awareness component into a tie, stressing its design as an accessory.

1. Introduction

Sensors are built into wearable computers to make them attentive for their users and usage environment, and to enable context-aware behavior. We suggest to realize sensor-based context-awareness rather as device-independent component or accessory. A wearable context-awareness component that integrates low-cost sensors is proposed. Simple methods are used to derive context information from sensor data. The derived context is application-independent and can be exploited by other wearable or personal technologies in a body network, for instance wearable computers, mobile phones, digital cameras, and personal digital assistants.

In this paper, we describe a study of wearable context-awareness. In this study we developed a wearable component that uses sensors to derive some application-independent contexts. We built this component into a tie, which is practical for placement of certain sensors, and which also stresses the component's design as accessory.

2. A Study of Wearable Context-Awareness

Context has many aspects as pointed out by [1], [2], [5]. Most reported work on context-awareness describes solutions for specific applications e.g. [3], [4], and it is evident that we lack the theoretical foundations and ontologies for general consideration of context. For a study of wearable context-awareness we chose to address a number of contexts that relate to how interruptible the user is. These contexts describe only a certain aspect of real world situations but they are general in the sense that they can be exploited by a range of applications. Such context is for instance implemented and used in the audio wearable described in [4], mimicking the human ability to recognize situations in which it is rude to interrupt, for

instance when a person is engaged in a conversation or giving a talk. Context information of this kind is also useful for other applications, for instance calendars, email notification, pagers and mobile phones can make use of any context that gives an indication of whether it is a good time to interrupt a user.

The specific contexts that we chose for our study are based on aural information: user speaking, others speaking, noisy, and quiet. And based on movement of the user: walking, running, stationary. Movement context was included as it gives an indication as to whether a user can be interrupted visually.

2.1. Design of the Context-Awareness Component

Our concept of a wearable context-awareness component stresses lightweight design in every sense. A key rationale is the use of low-cost sensors and lightweight processing in contrast to for instance approaches in computer vision. Lightweight design aims at implementation as small unobtrusive wearable, and also at realization as low-cost accessory to other wearable devices such as mobile phones [2]. See Figure 1 for an image of the context-awareness tie.

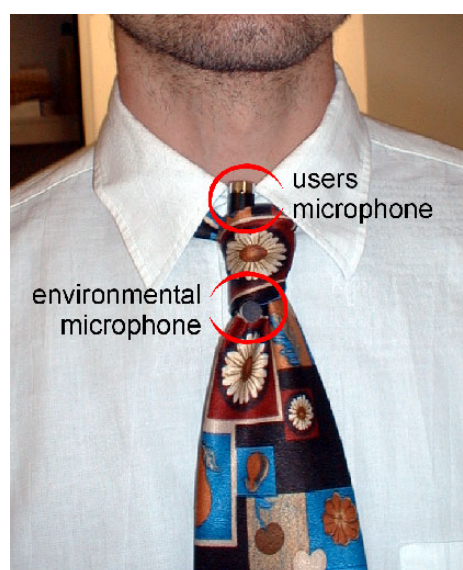

Figure 1: Context-Awareness Tie.

For recognition of aural and movement contexts, we integrated two microphones and an accelerometer in our design. One of the microphones is placed near the user's throat, the other pointing away from the user. With this configuration the distinction of speaker and environment is feasible with minimal processing cost. The acceleration sensor is used to discriminate whether a user is standing still, walking or running.

The sensor placement considerations led us to build the context-awareness component into a tie – it may be considered to build them into other accessories worn in similar ways (e.g. jewelry, neckerchief, or necklace). We also liked that a tie stresses the component's design as accessory rather than as stand-alone device.

2.2. Hardware

The hardware of our context-awareness component is build around a TINY-Tiger microcontroller, that offers four analog inputs and two serial lines. The two signals from the microphones are amplified and connected to the analog inputs. To measure the motion we used a two-axis accelerometer (Analog Devices ADXL202). The schematic of the component is depicted in Figure 2.

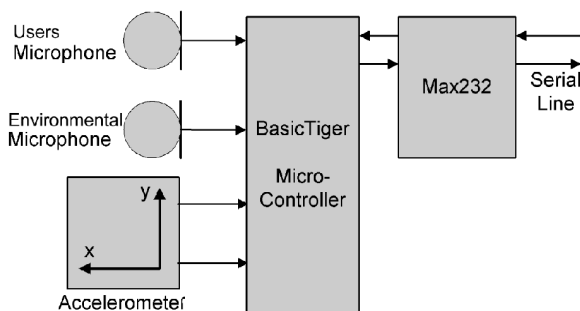

Figure 2: Schematic - Context-Awareness Device.

2.3. Software

The software is realized in Tiger-BASIC, a multitasking basic dialect for the TINY-Tiger. It reads and analyzes sensor data in a time window of about four seconds. The methods to analyze the signals are deliberately simple; they work within the time domain and are based on basic statistical measurements. Examples of methods and extracted features are:

- absolute average of signals:
~ volume of audio, ~ level of motion;
- distribution of distances between zero-crossings:
~ indication of frequency (sound and motion),
- distribution of maximum values over 20 ms: ~ low pass filter.

Based on the features calculated from sensor data the contexts are detected. This is implemented by a simple matrix multiplication on the microcontroller. The matrix is hardcoded and represents the weight set of a neural network that was trained with example data on a PC.

2.4. Protocol

The communication is based on a serial line connection using 9600 bit/s, in a simple request-reply manner. The client sends a request to the context-awareness component which sends back a reply with the current contexts, using the following protocol:

```
<request> ::= "GET\n" | "get\n".
<reply> ::= "(a:" <audio_ctxt> ";m:"
             <motion_ctxt> ") \n".
<audio_ctxt> ::= "n" | "q" | "s" | "l".
<motion_ctxt> ::= "s" | "w" | "r".
```

The semantic of the audio contexts is:

n = **n**oisy, q = **q**uiet, s = user **s**peaking,
l = others speaking (user **l**istening).

The semantic of the motion contexts is:

s = **s**tationary, w = **w**alking, r = **r**unning.

2.5. Results

Experimentation with the context-aware tie showed that contexts were recognized in a very reliable way. Both “user speaking” vs. “others speaking” and “stationary” vs. “walking” vs. “running” were discriminated correctly. A key finding is that sensor placement can be used effectively to increase reliability and to reduce required processing.

3. Conclusion and Further work

The presented study indicates the utility of a lightweight context-awareness component, that can be realized as wearable built into a tie or other clothing accessory to provide context for other personal technologies in a body network. Further work includes re-implementation of the component on a PIC microcontroller to reduce device cost and power consumption. It also includes investigation of further sensors and contexts, and integration with other devices in body networks based on short range RF.

4. References

- [1] Brown, P. J., Bovey, J. D., Chen, X. Context-Aware Applications: From the Laboratory to the Marketplace. IEEE Personal Communications, October 1997.
- [2] Esprit Project 26900. Technology for enabling Awareness (TEA). www.omega.it/tea/, 1998
- [3] Healey, J. and Picard, R.W. StartleCam: A Cybernetic Wearable Camera. Proceedings of the Second International Symposium on Wearable Computing, Pittsburgh, PA, October 19-20, 1998.
- [4] Sawhney, N., and S., Chris. "Nomadic Radio: A Spatialized Audio Environment for Wearable Computing." Proceedings of the International Symposium on Wearable Computing, Cambridge, MA, October 13-14, 1997.
- [5] Schmidt, A., Beigl, M., Gellersen, H.-W. There is more to context than location. Proc. of the Intl. Workshop on Interactive Applications of Mobile Computing (IMC98), Rostock, Germany, November 1998.